

ANNOUNCING!

# SEQUENCED GEAR SYSTEM FOR LANCAIRS

New installations & retrofit

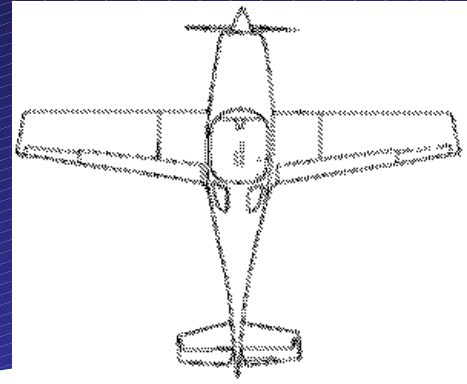

*Don't leave your gear doors twisting in the wind!*

The Sequenced Gear System closes the inner doors after the mains extend, **protecting the doors and hinges** from the slipstream and prop blast. Closing the doors also **reduces wind noise, drag, and damage from FOD.**

We use the **same technologies as the stock Lancair design** for maximum reliability, value, and ease of installation.

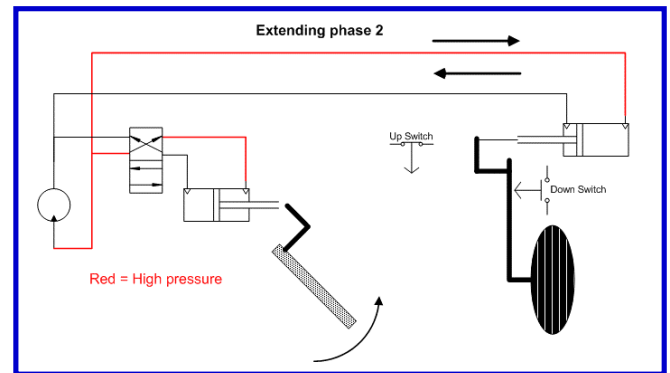

## Comprehensive Package, including:

- Detailed installation instructions, diagrams, and photos.
- All hydraulic components, including the fittings, reversing valve and a custom manifold block that greatly simplifies plumbing.
- All electrical components, including a DPDT gated landing gear toggle switch, weatherproof position-sensing switches, and reversing valve actuator assembly.
- A drilling template and mounting hardware for the positioning switches, reversing valve and manifold block.

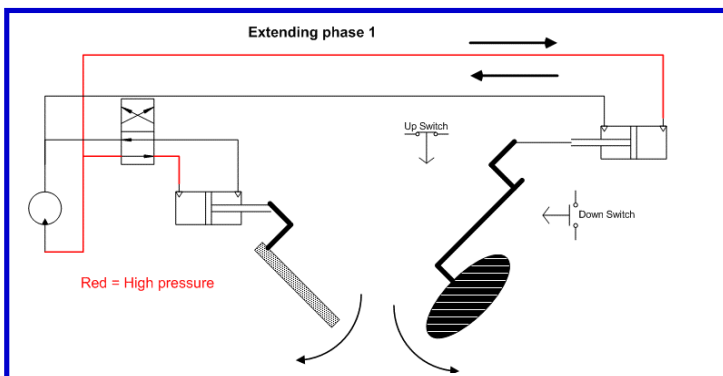

[www.ronk-air.com](http://www.ronk-air.com)

Ronkonkoma Aircraft Industries, LLC  
2805 Veterans Memorial Hwy, Suite 27  
Ronkonkoma, NY 11779  
(631) 672-9386

© 2004, All Rights Reserved